

FEATURES

- Complete acceleration measurement system on a single monolithic IC**
- Available in $\pm 120\text{ g}$ or $\pm 250\text{ g}$ output full-scale ranges**
- Full differential sensor and circuitry for high resistance to EMI/RFI**
- Environmentally robust packaging**
- Complete mechanical and electrical self-test on digital command**
- Output ratiometric to supply**
- Sensitive axes in the plane of the chip**
- High linearity (0.2% of full scale)**
- Frequency response down to dc**
- Low noise**
- Low power consumption (1.5 mA)**
- Tight sensitivity tolerance and 0 g offset capability**
- Largest available prefilter clipping headroom**
- 400 Hz, 2-pole Bessel filter**
- Single-supply operation**
- Compatible with Sn/Pb and Pb-free solder processes**

APPLICATIONS

- Vibration monitoring and control**
- Vehicle collision sensing**
- Shock detection**

GENERAL DESCRIPTION

The ADXL193 is a low power, complete single-axis accelerometer with signal conditioned voltage outputs that are all on a single monolithic IC. This product measures acceleration with a full-scale range of $\pm 120\text{ g}$ or $\pm 250\text{ g}$ (minimum). It can also measure both dynamic acceleration (vibration) and static acceleration (gravity).

The ADXL193 is a fourth-generation surface micromachined *iMEMS*[®] accelerometer from ADI with enhanced performance and lower cost. Designed for use in front and side impact airbag applications, this product also provides a complete cost-effective solution useful for a wide variety of other applications.

The ADXL193 is temperature stable and accurate over the automotive temperature range, with a self-test feature that fully exercises all the mechanical and electrical elements of the sensor with a digital signal applied to a single pin.

The ADXL193 is available in a 5 mm \times 5 mm \times 2 mm, 8-terminal ceramic LCC package.

FUNCTIONAL BLOCK DIAGRAM

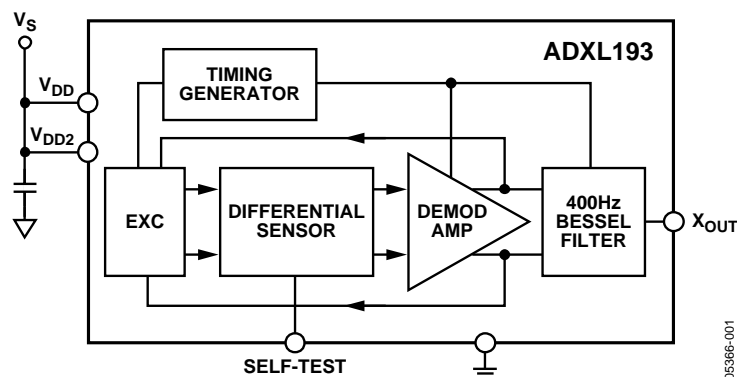

Figure 1.

Rev. A
Information furnished by Analog Devices is believed to be accurate and reliable. However, no responsibility is assumed by Analog Devices for its use, nor for any infringements of patents or other rights of third parties that may result from its use. Specifications subject to change without notice. No license is granted by implication or otherwise under any patent or patent rights of Analog Devices. Trademarks and registered trademarks are the property of their respective owners.

上海麦游电子科技有限公司
上海市普陀区府村路255号2号楼2层 200333
Tel:(86)-21-32030015 28816246 Fax:32030015
www.my-sensor.com
E-mail:lee@my-sensor.com sales@my-sensor.com

TABLE OF CONTENTS

Specifications.....	3	Power Supply Decoupling.....	8
Absolute Maximum Ratings.....	4	Self-Test	8
ESD Caution.....	4	Clock Frequency Supply Response	8
Pin Configuration and Function Descriptions.....	5	Signal Distortion	8
Theory of Operation	7	Outline Dimensions	9
Applications.....	8	Ordering Guide	9

REVISION HISTORY

5/05—Rev. 0 to Rev. A

SPECIFICATIONS¹

At $T_A = -40^\circ\text{C}$ to $+105^\circ\text{C}$, 5.0 V dc $\pm 5\%$, acceleration = 0 g; unless otherwise noted.

Table 1.

Parameter	Conditions	Model No. AD22282			Model No. AD22283			Unit
		Min	Typ	Max	Min	Typ	Max	
SENSOR								
Output Full-Scale Range	$I_{\text{OUT}} \leq \pm 100 \mu\text{A}$	120			250			g
Nonlinearity			0.2	2		0.2	2	%
Package Alignment Error				1			1	Degree
Cross-Axis Sensitivity			-5		+5	-5		+5
Resonant Frequency	$V_{\text{DD}} = 5 \text{ V}$, 100 Hz		24			24		kHz
Sensitivity, Ratiometric (Over Temperature)			17.1	18	18.9	7.6	8	8.4
OFFSET								
Zero-g Output Voltage (Over Temperature) ²	$V_{\text{OUT}} - V_{\text{DD}}/2$, $V_{\text{DD}} = 5 \text{ V}$	-125		+125	-100		+100	mV
NOISE								
Noise Density	10 Hz – 400 Hz, 5 V		3	10		5	15	mg/ $\sqrt{\text{Hz}}$
Clock Noise				5			5	
FREQUENCY RESPONSE								
-3 dB Frequency	Two-pole Bessel	360	400	440	360	400	440	Hz
-3 dB Frequency Drift	25°C to T_{MIN} or T_{MAX}		2			2		Hz
SELF-TEST								
Output Change (Cube vs. V_{DD}) ³	$V_{\text{DD}} = 5 \text{ V}$	400	500	600	200	250	300	mV
Logic Input High	$V_{\text{DD}} = 5 \text{ V}$	3.5			3.5			V
Logic Input Low	$V_{\text{DD}} = 5 \text{ V}$			1			1	V
Input Resistance	Pull-down resistor to GND	30	50		30	50		k Ω
OUTPUT AMPLIFIER								
Output Voltage Swing	$I_{\text{OUT}} = \pm 400 \mu\text{A}$	0.25		$V_{\text{DD}} - 0.25$	0.25		$V_{\text{DD}} - 0.25$	V
Capacitive Load Drive			1000			1000		
PREFILTER HEADROOM								
CFSR @ 400 kHz			800			1400		g
POWER SUPPLY (V_{DD})								
Functional Range		4.75		5.25	4.75		5.25	V
Quiescent Supply Current	$V_{\text{DD}} = 5 \text{ V}$	3.5	1.5	2	3.5	1.5	2	V
TEMPERATURE RANGE		-40		+125	-40		+125	$^\circ\text{C}$

¹ All minimum and maximum specifications are guaranteed. Typical specifications are not guaranteed.

² Zero g output is ratiometric.

³ Self-test output at $V_{\text{DD}} = (\text{Self-Test Output at } 5 \text{ V}) \times (V_{\text{DD}}/5 \text{ V})^3$.

ABSOLUTE MAXIMUM RATINGS

Table 2.

Parameter	Rating
Acceleration (Any Axis, Unpowered)	4,000 g
Acceleration (Any Axis, Powered)	4,000 g
V _S	-0.3 V to +7.0 V
All Other Pins	(COM - 0.3 V) to (V _S + 0.3 V)
Output Short-Circuit Duration (Any Pin to Common)	Indefinite
Operating Temperature Range	-65°C to +150°C
Storage Temperature	-65°C to +150°C

Stresses above those listed under Absolute Maximum Ratings may cause permanent damage to the device. This is a stress rating only; functional operation of the device at these or any other conditions above those indicated in the operational section of this specification is not implied. Exposure to absolute maximum rating conditions for extended periods may affect device reliability.

ESD CAUTION

ESD (electrostatic discharge) sensitive device. Electrostatic charges as high as 4000 V readily accumulate on the human body and test equipment and can discharge without detection. Although this product features proprietary ESD protection circuitry, permanent damage may occur on devices subjected to high energy electrostatic discharges. Therefore, proper ESD precautions are recommended to avoid performance degradation or loss of functionality.



PIN CONFIGURATION AND FUNCTION DESCRIPTIONS

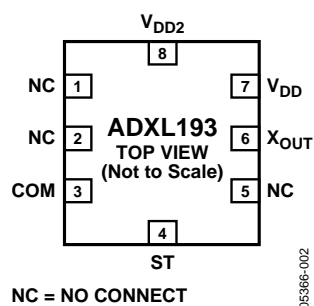

Figure 2. Pin Configuration

Table 3. Pin Function Descriptions

Pin No.	Mnemonic	Description
1	NC	Do Not Connect
2	NC	Do Not Connect
3	COM	Common
4	ST	Self-Test
5	NC	Do Not Connect
6	X _{OUT}	X Channel Output
7	V _{DD}	3.5 V to 6 V
8	V _{DD2}	3.5 V to 6 V

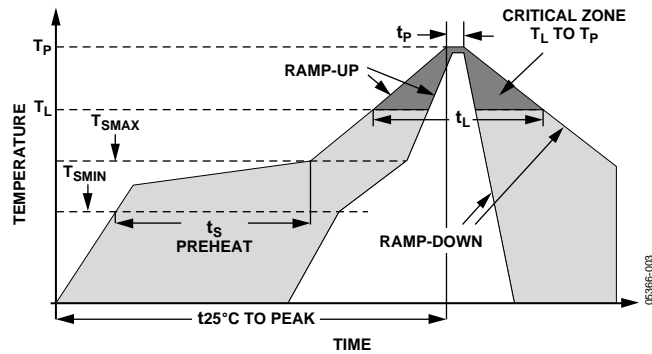

Figure 3. Recommended Soldering Profile

Table 4. Recommended Soldering Profile

Profile Feature	Sn63/Pb37	Pb-Free
AVERAGE RAMP RATE (T_L TO T_P)	3°C/s max	3°C/s max
PREHEAT		
Minimum Temperature (T_{SMIN})	100°C	150°C
Maximum Temperature (T_{SMAX})	150°C	200°C
TIME (T_{SMIN} TO T_{SMAX}), t_s	60 s – 120 s	60 s – 150 s
T_{SMAX} TO T_L		
Ramp-Up Rate	3°C/s	3°C/s
TIME MAINTAINED ABOVE LIQUIDOUS (T_L)		
Liquidous Temperature (T_L)	183°C	217°C
Time (t_L)	60 s – 150 s	60 s – 150 s
PEAK TEMPERATURE (T_P)	240°C + 0°C/-5°C	260°C + 0°C/-5°C
TIME WITHIN 5°C OF ACTUAL PEAK TEMPERATURE (t_p)	10 s – 30 s	20 s – 40 s
RAMP-DOWN RATE	6°C/s max	6°C/s max
TIME 25°C TO PEAK TEMPERATURE	6 min max	8 min max

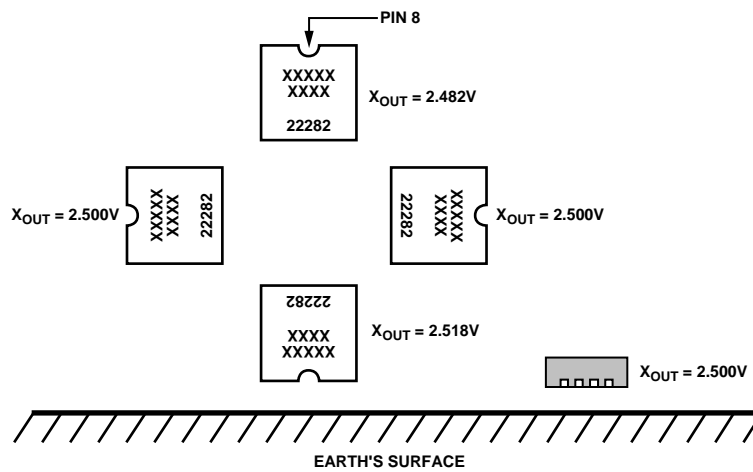

Figure 4. Output Response vs. Orientation

THEORY OF OPERATION

The ADXL193 provides a fully differential sensor structure and circuit path, resulting in the industry's highest resistance to EMI/RFI effects. This latest generation uses electrical feedback with zero-force feedback for improved accuracy and stability. The sensor resonant frequency is significantly higher than the signal bandwidth set by the on-chip filter, avoiding the signal analysis problems caused by resonant peaks near the signal bandwidth.

Figure 5 is a simplified view of one of the differential sensor elements. Each sensor includes several differential capacitor unit cells. Each cell is composed of fixed plates attached to the substrate and movable plates attached to the frame. Displacement of the frame changes the differential capacitance, which is measured by the on-chip circuitry.

Complementary 400 kHz square waves drive the fixed plates. Electrical feedback adjusts the amplitudes of the square waves such that the ac signal on the moving plates is 0. The feedback signal is linearly proportional to the applied acceleration. This unique feedback technique ensures that there is no net electrostatic force applied to the sensor. The differential feedback control signal is also applied to the input of the filter, where it is filtered and converted to a single-ended signal.

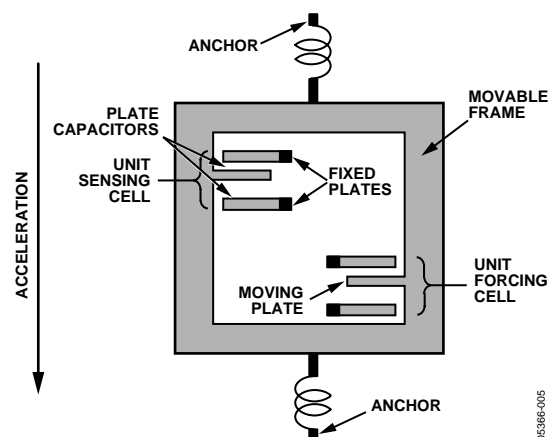

Figure 5. Simplified View of Sensor Under Acceleration

05366-005

APPLICATIONS

POWER SUPPLY DECOUPLING

For most applications, a single 0.1 μF capacitor, C_{DC} , adequately decouples the accelerometer from noise on the power supply. However, in some cases, particularly where noise is present at the 400 kHz internal clock frequency (or any harmonic thereof), noise on the supply can cause interference on the ADXL193's output. If additional decoupling is needed, a 50 Ω (or smaller) resistor or ferrite bead can be inserted in the supply line. Additionally, a larger bulk bypass capacitor (in the 1 μF to 4.7 μF range) can be added in parallel to C_{DC} .

SELF-TEST

The fixed fingers in the forcing cells are normally kept at the same potential as that of the movable frame. When the self-test digital input is activated, the voltage on the fixed fingers on one side of the moving plate in the forcing cells is changed. This creates an attractive electrostatic force, which causes the frame to move toward those fixed fingers. The entire signal channel is active; therefore, the sensor displacement causes a change in V_{OUT} . The ADXL193's self-test function is a comprehensive method of verifying the operation of the accelerometer.

Because electrostatic force is independent of the polarity of the voltage across capacitor plates, a positive voltage is applied in half of the forcing cells, and its complement in the other half of the forcing cells. Activating self-test causes a step function force to be applied to the sensor, while the capacitive coupling term is canceled. The ADXL193 has improved self-test functionality, including excellent transient response and high speed switching capability. Arbitrary force waveforms can be applied to the sensor by modulating the self-test input, such as test signals to measure the system frequency response, or even crash signals to verify algorithms within the limits of the self-test swing.

The ST pin should never be exposed to voltages greater than $V_s + 0.3$ V. If this cannot be guaranteed due to the system design (for instance, if there are multiple supply voltages), then a low V_F clamping diode between ST and V_s is recommended.

CLOCK FREQUENCY SUPPLY RESPONSE

In any clocked system, power supply noise near the clock frequency may have consequences at other frequencies. An internal clock typically controls the sensor excitation and the signal demodulator for micromachined accelerometers.

If the power supply contains high frequency spikes, they may be demodulated and interpreted as an acceleration signal. A signal appears as the difference between the noise frequency and the demodulator frequency. If the power supply spikes are 100 Hz away from the demodulator clock, there is an output term at 100 Hz. If the power supply clock is at exactly the same frequency as the accelerometer clock, the term appears as an offset.

If the difference frequency is outside of the signal bandwidth, the filter attenuates it. However, both the power supply clock and the accelerometer clock may vary with time or temperature, which can cause the interference signal to appear in the output filter bandwidth.

The ADXL193 addresses this issue in two ways. First, the high clock frequency eases the task of choosing a power supply clock frequency such that the difference between it and the accelerometer clock remains well outside of the filter bandwidth. Second, the ADXL193 is the only micromachined accelerometer to have a fully differential signal path, including differential sensors. The differential sensors eliminate most of the power supply noise before it reaches the demodulator. Good high frequency supply bypassing, such as a ceramic capacitor close to the supply pins, also minimizes the amount of interference.

The clock frequency supply response (CFSR) is the ratio of the response at V_{OUT} to the noise on the power supply near the accelerometer clock frequency. A CFSR of 3 means that the signal at V_{OUT} is 3 \times the amplitude of an excitation signal at V_{DD} near the accelerometer internal clock frequency. This is analogous to the power supply response, except that the stimulus and the response are at different frequencies. The ADXL193's CFSR is 10 \times better than a typical single-ended accelerometer system.

SIGNAL DISTORTION

Signals from crashes and other events may contain high amplitude, high frequency components. These components contain very little useful information and are reduced by the 2-pole Bessel filter at the output of the accelerometer. However, if the signal saturates at any point, the accelerometer output does not look like a filtered version of the acceleration signal.

The signal may saturate anywhere before the filter. For example, if the resonant frequency of the sensor is low, the displacement per unit acceleration is high. The sensor may reach the mechanical limit of travel if the applied acceleration is high enough. This can be remedied by locating the accelerometer where it does not see high values of acceleration and by using a higher resonant frequency sensor, such as the ADXL193.

Also, the electronics may saturate in an overload condition between the sensor output and the filter input. Ensuring that internal circuit nodes operate linearly to at least several times the full-scale acceleration value can minimize electrical saturation. The ADXL193 circuit is linear to approximately 8 \times full scale.

OUTLINE DIMENSIONS

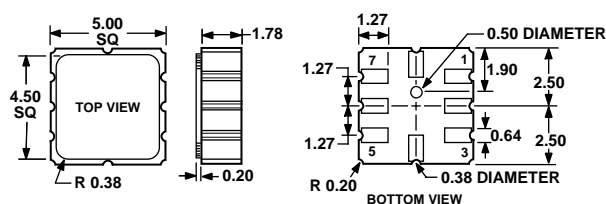

Figure 6. 8-Terminal Ceramic Leadless Chip Carrier [LCC]
(E-8)
Dimensions shown in millimeters

ADXL193 ORDERING GUIDE

Model ¹	Parts per Reel	Measurement Range	Specified Voltage (V)	Temperature Range	Package Description	Package Option
AD22282-A-R2	250	±120 g	5	-40°C to +125°C	8-Terminal Ceramic Leadless Chip Carrier	E-8
AD22282-A	3000	±120 g	5	-40°C to +125°C	8-Terminal Ceramic Leadless Chip Carrier	E-8
AD22283-B-R2	250	±250 g	5	-40°C to +125°C	8-Terminal Ceramic Leadless Chip Carrier	E-8
AD22283-B	3000	±250 g	5	-40°C to +125°C	8-Terminal Ceramic Leadless Chip Carrier	E-8

¹ All models are on tape and reel and are Pb-free parts.

ADXL193

NOTES

NOTES

ADXL193

NOTES

上海麦游电子科技有限公司
上海市普陀区府村路255号2号楼2层 200333 Tel:(86)-21-32030015 28816246 Fax:32030015
www.my-sensor.com E-mail:lee@my-sensor.com sales@my-sensor.com