

## Accelerometers

### Analog Output

MSA-H1-13.3 — **Single Axis X**



---

## APPLICATIONS

***Motion Detection/Monitoring***

***Vibration Detection/Monitoring***

***Vehicle Active Suspension Systems***

***Vehicle Crash Detection***

***Engine Misfire Detection***

---

## FEATURES

Lead-free Solderability

High Shock Survivability

Excellent Temperature Performance

Low Noise Density

Low Power Consumption

User Definable Bandwidth

Factory Programmable Offset  
and Sensitivity

Self-test Function

---

## PROPRIETARY TECHNOLOGY

These high-performance silicon micromachined linear accelerometers and inclinometers consists of a sensor element and an ASIC packaged in a standard 16-pin SOIC wide-body package. The sensor element is fabricated from single-crystal silicon with proprietary Deep Reactive Ion Etching (DRIE) processes, and is protected from the environment by a hermetically-sealed silicon cap wafer at the wafer level.

The MSA-H series is designed to provide a high signal-to-noise ratio with excellent performance over temperature. Sensitivity is factory programmable allowing customization for applications requiring  $\pm 10.0g$  to  $\pm 40.0g$  ranges. Sensor bandwidth is user-definable.

The sensor element functions on the principle of differential capacitance. Acceleration causes displacement of a silicon structure resulting in a change in capacitance. An ASIC, using a standard CMOS manufacturing process, detects and transforms changes in capacitance into an analog output voltage, which is proportional to acceleration. The sense element design utilizes common mode cancellation to decrease errors from process variation and environmental stress.

## PRODUCT SPECIFICATIONS

PERFORMANCE SPECIFICATIONS			
PARAMETERS	UNITS	MSA-H1-13.3	CONDITION
Range	g	13.3	Factory programmable
Sensitivity <sup>1</sup>	mV/g	150	Factory programmable
Offset vs. Temp.	mV	±110	Over temp range
	°C	-40 to 125 <sup>2</sup>	
Sensitivity Error	%	±2.0 typical (±3.0 max)	Over temp range
Span	mV	±2000	
Noise Density	$\mu\text{g} / \sqrt{\text{Hz}}$	120 typical (200 max)	DC..100Hz
Bandwidth <sup>3</sup>	Hz	500 standard	-3dB
		250, 1000 (preset)	
Non-Linearity	% of FS	±0.4 typical (±1.0 max)	
Ratiometric Error	%	±1.7 typical (±2.0 max)	
Cross-Axis Sensitivity	%	±2.0 typical (±3.0 max)	
Power Supply	V	5.0 ± 0.25	
	V	-0.3 (min) 7.0 (max)	Absolute min/max
	mA	3.5 typical (5.0 max)	Current draw @ 5V

ENVIRONMENTAL SPECIFICATIONS			
PARAMETERS	UNITS	MSA-H1-13.3	CONDITION
Operating Temperature	°C	-40 to 125	Powered
Storage Temperature	°C	-55 to 150	Unpowered
Mechanical Shock	g	5000	Powered or unpowered, 0.5msec haversine
ESD	V	3000	Human body model

### Notes

<sup>1</sup> Custom sensitivities from 80mV/g through 200mV/g available.

<sup>2</sup> Temperature range for specified offset.

<sup>3</sup> The internal filter can be bypassed. Lower bandwidth can be achieved by using the external C<sub>2</sub> (see application note on page 3).

## FUNCTIONAL DIAGRAM

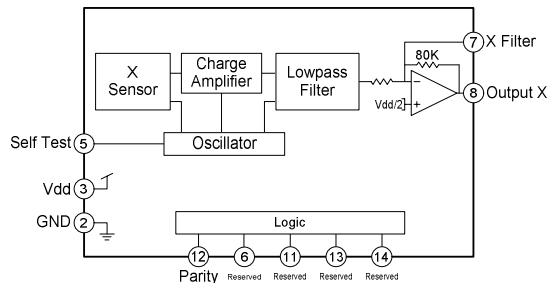

## 16-PIN SOIC OVERMOLDED PACKAGE

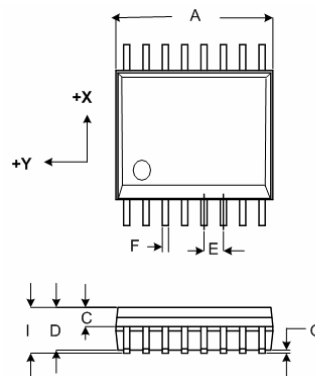

Dimension	Inches	Millimeters
A	0.406	10.31
B	0.296	7.52
C	0.043	1.09
D	0.096	2.44
E	0.050	1.27
F	0.016	0.41
G	0.007	0.18
H	0.406	10.31
I	0.103	2.62

### Notes

- When device is accelerated in +X direction, the corresponding output will increase.
- The packaged device weighs .44 grams.

## APPLICATION SCHEMATIC &amp; PIN FUNCTION TABLE

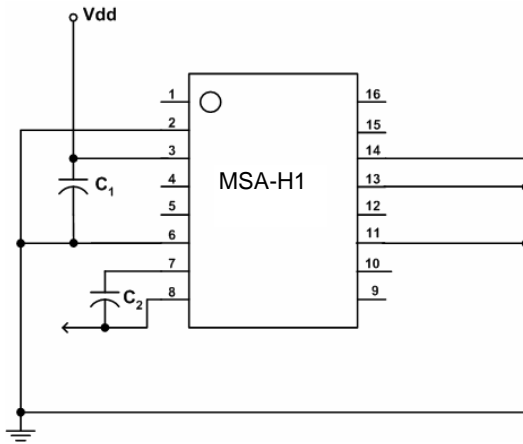

Pin	Function
1	DNC
2	GND
3	Vdd (+5 V)
4	DNC
5	Self Test
6	Reserved
7	X Filter
8	Output X
9	DNC
10	DNC
11	Reserved
12	Parity
13	Reserved
14	Reserved
15	DNC
16	DNC

**Definitions**

- X Filter** An external capacitor,  $C_2$ , tied across pins #7 and #8, is used to set the -3dB filter point for the sensor output.
- DNC** Do not connect.
- Parity** Checks EEPROM for parity error.
- Reserved** For factory use; recommend grounding.
- Self-Test** The output of a properly functioning part will increase by at least 1.8V when 5V is applied to the self-test pin (#5).

**Application Design Equations**

The bandwidth,  $f_{BW}$ , can be adjusted with a capacitor,  $C_2$ , across pins #7 and #8. The response is single pole. Given a desired bandwidth,  $f_{BW}$ , the filter capacitor,  $C_2$ , is determined by:

$$C_2 = \frac{1.99 \times 10^{-6}}{f_{BW}}$$

**Notes**

1. Recommend using 0.1  $\mu$ F for decoupling capacitor  $C_1$ .
2. An evaluation board is available upon request.

## ORDERING GUIDE

Product	Axis of Sensitivity	Range	Sensitivity (mV/g)	Offset (V)	Operating Voltage (V)	Temperature	Package
MSA-H1-13.3	X	13.3g	150	2.65	5	-40 to +125 °C	16-pin SOIC Overmolded