

MSA-H2/3-2 Series Data Sheet

Accelerometers and Inclinometers

Analog Output

MSA-H2-2 — **Dual-Axis XY**

MSA-H3-2 — **Tri-Axis XYZ**

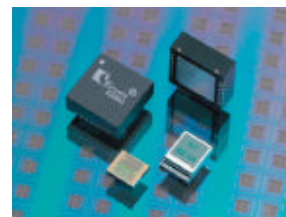

APPLICATIONS

Drop Detection

Cell Phones and Handheld PDAs

Gesture Recognition

Gaming and Game Controllers

Inclination and Tilt Sensing

Universal Remote Controls

Image Stabilization

Theft and Accident Alarms

Sports Diagnostics

GPS Recognition Assist

Vibration Analysis

Hard-drive Protection

Static or Dynamic Acceleration

Pedometers

Inertial Navigation and Dead(uctive) Reckoning

Computer Peripherals

Cameras and Video Equipment

FEATURES

Ultra-Small Package — 5x5x1.8mm DFN

Precision Tri-axis Orthogonal Alignment

Lead-free Solderability

High Shock Survivability

Excellent Temperature Performance

Very Low Noise Density

Low Power Consumption

Power Shutdown Pin

High-Speed Power-Up

User Definable Bandwidth

Factory Programmable Offset
and Sensitivity

Self-test Function

PROPRIETARY TECHNOLOGY

These high-performance silicon micromachined linear accelerometers and inclinometers consists of a sensor element and an ASIC packaged in a 5x5x1.8mm Dual Flat No-lead (DFN). The sensor element is fabricated from single-crystal silicon with proprietary Deep Reactive Ion Etching (DRIE) processes, and is protected from the environment by a hermetically-sealed silicon cap wafer at the wafer level.

The MSA-H series is designed to provide a high signal-to-noise ratio with excellent performance over temperature. These sensors can accept supply voltages between 2.5V and 5.5V. Sensitivity is factory programmable allowing customization for applications requiring $\pm 1.0g$ to $\pm 6.0g$ ranges. Sensor bandwidth is user-definable.

The sensor element functions on the principle of differential capacitance. Acceleration causes displacement of a silicon structure resulting in a change in capacitance. An ASIC, using a standard CMOS manufacturing process, detects and transforms changes in capacitance into an analog output voltage, which is proportional to acceleration. The sense element design utilizes common mode cancellation to decrease errors from process variation and environmental stress.

上海麦游电子科技有限公司

上海市普陀区府村路255号2号楼2层 200333

Tel:(86)-21-32030015 28816246 Fax:32030015

www.my-sensor.com E-mail:lee@my-sensor.com sales@my-sensor.com

PRODUCT SPECIFICATIONS

PERFORMANCE SPECIFICATIONS ¹			
PARAMETERS	UNITS	MSA-H2-2 MSA-H3-2	CONDITION
Range	g	±2.0	Factory programmable
Sensitivity ²	mV/g	660	@3.3V
0g Offset vs. Temp.	mV	±100	Over temp range
	°C	-40 to 85 ³	
Sensitivity vs. Temp	%	±2.0 typical (±3.0 max)	Over temp range
Span	mV	±1320	@ 3.3 V
Noise	$\mu\text{g}/\sqrt{\text{Hz}}$	35 (x and y) 65 (z) typical	@ 500 Hz
Bandwidth ⁴	Hz	0 to 3000 max (x and y)	-3dB
		0 to 1500 max (z)	
Output Resistance ⁵	Ω	32K typical	
Non-Linearity	% of FS	±0.1 typical (±0.5max)	
Ratiometric Error	%	±1.0 typical (±1.5 max)	
Cross-axis Sensitivity	%	±2.0 typical (±3.0 max)	
Power Supply	V	2.5 to 5.5 ⁶	
	V	-0.3 (min) 7.0 (max)	Absolute min/max
	mA	1.5 typical (1.8 max)	Current draw @ 3.3V
	μA	<10	Shutdown pin connected to GND
	ms	1.6	Power-up time @ 500 Hz ⁶
ENVIRONMENTAL SPECIFICATIONS			
PARAMETERS	UNITS	MSA-H2/3	CONDITION
Operating Temperature	°C	-40 to 125 ⁷	Powered
Storage Temperature	°C	-55 to 150	Unpowered
Mechanical Shock	g	4600	Powered or unpowered, 0.5 msec halversine
ESD	V	3000	Human body model

Notes

- ¹ The performance parameters are programmed and tested at 3.3 volts. However, the device can be powered from 2.5 V to 5.5 V. Performance parameters will change with supply voltage variations.
- ² Custom sensitivities from 1g to 6g available.
- ³ Temperature range for specified offset.
- ⁴ Lower bandwidth can be achieved by using the external C₂, C₃, and C₄ (see application note on page 3).
- ⁵ 32K Ω resistor connects the output amplifier to the output pin. Resistive loading may reduce sensitivity or cause a shift in offset. Maintaining a load resistance at 3.2M Ω will prevent appreciable changes.
- ⁶ The power-up time will increase or decrease according to bandwidth.
- ⁷ 0g offset and sensitivity change linearly with temperature. Within the extended temperature range of -40°C to 125°C, the maximum 0g offset tolerance is ±167 mV and the maximum sensitivity is ±5%.

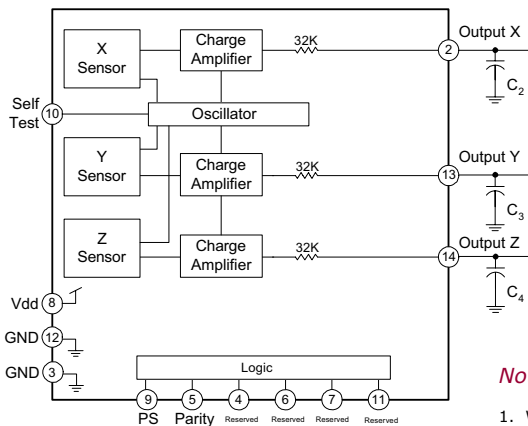
FUNCTIONAL DIAGRAM**Note**

1. When device is accelerated in +X, +Y or +Z direction, the corresponding output will increase.

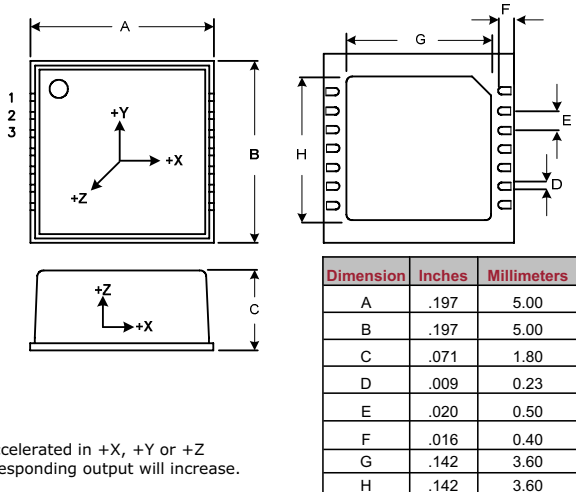
5x5x1.8mm DFN PACKAGE

APPLICATION SCHEMATIC & PIN FUNCTION TABLES

Pin	Dual-Axis Function
1	DNC
2	Output X
3	GND
4	Reserved
5	Parity
6	Reserved
7	Reserved
8	Vdd
9	PS
10	Self Test
11	Reserved
12	GND
13	Output Y
14	DNC

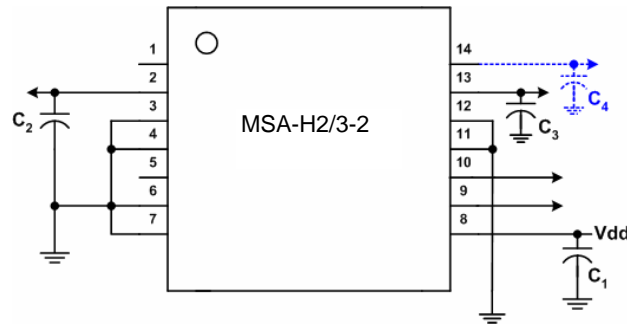

Pin	Tri-Axis Function
1	DNC
2	Output X
3	GND
4	Reserved
5	Parity
6	Reserved
7	Reserved
8	Vdd
9	PS
10	Self Test
11	Reserved
12	GND
13	Output Y
14	Output Z

Definitions

C₂, C₃, C₄ An external capacitor is used to set the -3dB filter point for each sensor output.

DNC Do not connect.

f_{BW} Sensor bandwidth frequency needed in application (typ. 10Hz to 1500Hz).

Parity Checks EEPROM for parity error.

PS Power shutdown pin. When the PS pin is connected to GND or left floating, the MSA-H is shutdown and drawing very little power. When the PS pin is tied to Vdd, the unit is fully functional.

Reserved For factory use; recommend grounding.

Self Test The output of a properly functioning part will increase by at least 1g when Vdd is applied to the self-test pin (#10).

Application Design Equations

In a typical application, the desired bandwidth will be determined by the fastest signal needing to be measured. Use this equation to calculate C₂, C₃ and C₄ and for the sensor:

$$C_2 = C_3 = C_4 = \frac{1}{2 * \pi * 32000 * f_{BW}}$$

Notes

1. Recommend using 0.1 μF for decoupling capacitor C₁.
2. Do not connect pin #14 on the dual-axis device.
3. An evaluation board is available upon request.

ORDERING GUIDE

Product	Axis(es) of Sensitivity	Range	Sensitivity (mV/g)	Offset (V)	Operating Voltage (V)	Temperature	Package
MSA-H2-2	XY	2g	660	1.65	3.3	-40 to +85 °C	5x5x1.8mm DFN
MSA-H3-2	XYZ	2g	660	1.65	3.3	-40 to +85 °C	5x5x1.8mm DFN