

Accelerometers

VIBRATION, HF SERIES

- ▼ Low Noise, Wide Bandwidth
- ▼ Easy to Use
- ▼ High Frequency Vibration Sensor
- ▼ ± 10 g and ± 100 g Ranges

Applications

- ▼ Vehicle and Engine Testing
- ▼ Shock Recording
- ▼ Predictive Maintenance
- ▼ Industrial Vibration Monitoring



HF Series

The HF Series accelerometers are precision vibration sensors based on an advanced piezoelectric material integrated with signal conditioning (charge amp) and current regulation electronics. The sensor features low noise, 300 μ grms, and wide bandwidth, 0.3 - 10,000 Hz. Unlike the other Crossbow accelerometer series, the HF Series does not have a DC response, which means the unit will not respond to gravity or other very low frequency (<0.3 Hz) signals.

An unregulated +6 to +30 VDC power supply can be used. The output signal span is ± 1 V centered about 2.5 V. The 2.5 V signal is the zero-g voltage offset. This interface eliminates cumbersome and costly interface electronics, e.g., battery powered and line powered signal conditioners.

The sensor is an excellent choice for vibration monitoring of all kinds: vehicle and engine testing, shock recording, predictive maintenance, industrial vibration monitoring, acoustic and high frequency measurements.

The sensor is delivered with a calibration sheet which standardizes the sensitivity to within 2%. The sensor is available in two packages, a standard nylon package, and an optional high temperature aluminum package.

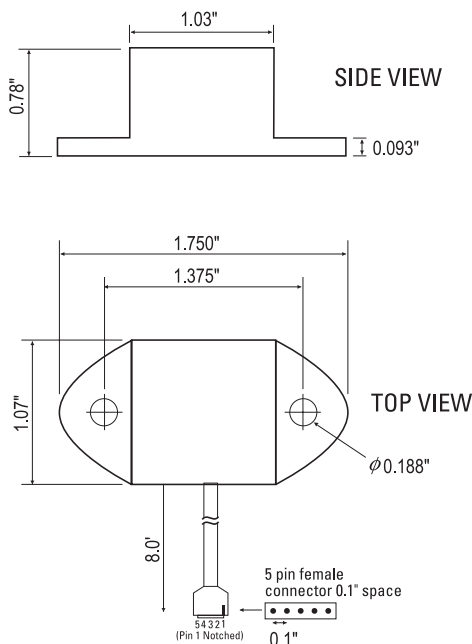

Specifications	CXL10HF1Z	CXL10HF3	CXL100HF1Z	CXL100HF3
Performance				
Input Range (g) ¹	± 10	± 10	± 100	± 100
Sensitivity (mV/g) ¹	± 100	± 100	± 10	± 10
Transverse Sensitivity (% FS)	5	5	5	5
Non-Linearity (% of FS)	1	1	1	1
Sensitivity Drift /Temp (%/°C)	0.18	0.18	0.18	0.18
Broadband Noise (µg rms)	300	300	300	300
Bandwidth (Hz) ²	0.3-10,000	0.3-10,000	0.3-10,000	0.3-10,000
Start Up Time (sec) ³	2.5	2.5	2.5	2.5
Environment				
Nylon Package				
Oper. Temp. Range (°C)	-40 to +85	-40 to +85	-40 to +85	-40 to +85
Storage Temp. Range (°C)	-50 to +85	-50 to +85	-50 to +85	-50 to +85
High Temperature Casing				
Oper. Temperature (°C)	-40 to +125	-40 to +125	-40 to +125	-40 to +125
Storage Temperature (°C)	-50 to +125	-50 to +125	-50 to +125	-50 to +125
Shock (g) ⁴	5000	5000	5000	5000
Electrical				
Voltage Mode				
Supply Voltage (VDC)	6 - 30	6 - 30	6 - 30	6 - 30
Supply Current (mA)	< 6	< 7	< 6	< 7
Zero g Output (VDC)	2.5 ± 1	2.5 ± 1	2.5 ± 1	2.5 ± 1
Span Voltage (V)	± 1	± 1	± 1	± 1
Physical				
Standard package				
Size (in)	0.78 x 1.75 x 1.07	0.78 x 1.75 x 1.07	0.78 x 1.75 x 1.07	0.78 x 1.75 x 1.07
Size (cm)	1.98 x 4.45 x 2.72	1.98 x 4.45 x 2.72	1.98 x 4.45 x 2.72	1.98 x 4.45 x 2.72
Weight	1.59 oz (45 gm)	1.59 oz (45 gm)	1.59 oz (45 gm)	1.59 oz (45 gm)
Aluminum package				
Size (in)	0.95 x 2.00 x 1.20	0.95 x 2.00 x 1.20	0.95 x 2.00 x 1.20	0.95 x 2.00 x 1.20
Size (cm)	2.41 x 5.08 x 3.05	2.41 x 5.08 x 3.05	2.41 x 5.08 x 3.05	2.41 x 5.08 x 3.05
Weight	2.47 oz (70 gm)	2.47 oz (70 gm)	2.47 oz (70 gm)	2.47 oz (70 gm)



Pin	Color	Function
1	Red	Power In
2	Black	Ground
3	White	X-axis Out
4	Yellow	Y-axis Out
5	Green	Z-axis Out

Pin Diagram

- Notes
¹ ±2%, Calibration sheet provided
² ±3dB, AC coupled sensor; Maximum Frequency Response - package and mounting dependent.
³ within 10%
⁴ 1 ms half sine

All frequency break points are -3 dB, single pole, -6 dB per octave roll-off. Non-linearity is the deviation from a best fit straight line at full scale. Transverse sensitivity is error measured in the primary axis output created by forces induced in the orthogonal axis. Transverse sensitivity error is primarily due to the effects of misalignment. Specifications subject to change without notice

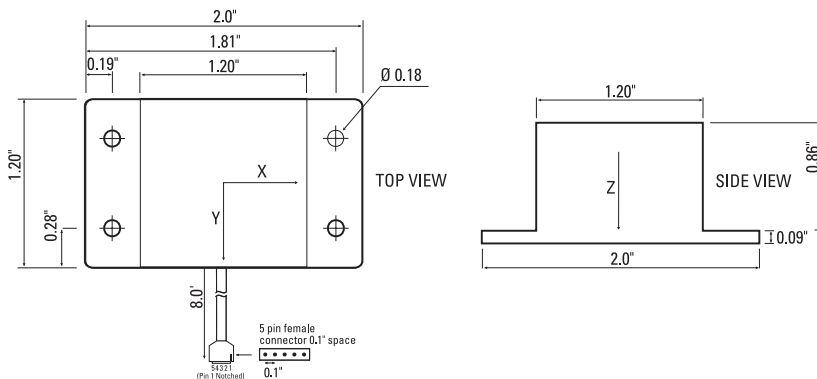

High Temperature Package



Ordering Information

Model	Axes	Span (g)	Sensitivity (mV/g)	Bandwidth (Hz)
CXL10HF1Z	Z	± 10	± 100	0.3-10,000
CXL10HF3	TRI	± 10	± 100	0.3-10,000
CXL100HF1Z	Z	± 100	± 10	0.3-10,000
CXL100HF3	TRI	± 100	± 10	0.3-10,000
OPTIONS				
-AL		High Temperature Package (see package drawing above)		

accelerometers