

# Accelerometers

## GENERAL PURPOSE, LP SERIES

- ▼ High Performance, 1-Axis and 3-Axis Accelerometers
- ▼ Small, Low-Cost
- ▼ Reliable Packaging with Screw-Down Mounting
- ▼ Factory Calibrated

## Applications

- ▼ Automotive Testing
- ▼ Instrumentation
- ▼ Equipment Monitoring



## LP Series

The LP Series accelerometers are low cost, general purpose, linear acceleration and/or vibration sensors available in ranges of  $\pm 4$  g,  $\pm 10$  g,  $\pm 25$  g,  $\pm 50$  g, and  $\pm 100$  g. Common applications are automotive testing, instrumentation, and equipment monitoring. The LP Series sensing element is a silicon micro-machined capacitive beam. The capacitive beam is held in force balance for full scale non-linearity of less than 0.2 %.

The LP Series offers wide dynamic range, has excellent frequency response, operates on a single +5 VDC power supply, and is easy to interface to standard data acquisition systems. The scale factor and the 0 g output level are both ratiometric to the power supply hence the accelerometer and any following circuitry will track each other if the supply voltage varies. Alternatively, by specifying the -R option, an unregulated 8-30 V power supply can be used.

The LP Series sensors provide a direct high-level analog voltage output. The output requires no external signal conditioning electronics and may be directly interfaced to an A/D or other data acquisition hardware.

Compared to traditional piezoelectric and piezoresistive accelerometer technologies, the silicon micro-machined sensors offer equivalent performance at a significantly lower cost.

The LP Series is offered with a standard 5-pin female connector. The highly flexible, low-mass cable prevents disruption of the measurement.

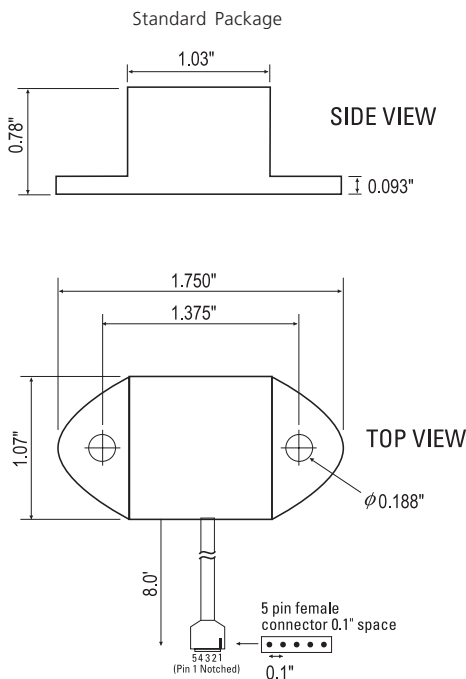

Specifications	CXL04LP1 CXL04LP1Z CXL04LP3	CXL10LP1 CXL10LP1Z CXL10LP3	CXL25LP1 CXL25LP1Z CXL25LP3	CXL50LP1 CXL50LP1Z CXL50LP3	CXL100LP1Z	Remarks
<b>Performance</b>						
Input Range (g)	± 4	± 10	± 25	± 50	± 100	± 5%
Zero g Drift (g)	± 0.2	± 0.2	± 0.2	± 0.2	± 1.0	0°C to 70°C
Sensitivity (mV/g)	500 ± 25	200 ± 10	80 ± 4	40 ± 2	20 ± 4	
Transverse Sensitivity (% Span)	± 5	± 5	± 5	± 5	± 5	
Non-Linearity (% FS)	± 0.2	± 0.2	± 0.2	± 0.2	± 0.2	typical
Alignment Error (deg)	± 2	± 2	± 2	± 2	± 2	typical
Noise (mg rms)	10	10	10	50	80	typical
Bandwidth (Hz) <sup>1</sup>	DC -100	DC -100	DC -100	DC -100	DC -100	
<b>Environment</b>						
Operating Temp. Range (°C)	-40 to +85	-40 to +85	-40 to +85	-40 to +85	-40 to +85	
Shock (g)	2000	2000	2000	2000	2000	
<b>Electrical</b>						
Supply Voltage (Volts)	+ 5.0	+ 5.0	+ 5.0	+ 5.0	+ 5.0	
Supply Voltage -R option (VDC)	+ 8.0 to 30	+ 8.0 to 30	+ 8.0 to 30	+ 8.0 to 30	+ 8.0 to 30	
Supply Current (mA)	5/axis	5/axis	5/axis	5/axis	5/axis	typical
Zero g Output (Volts)	+ 2.5 ± 0.1	+ 2.5 ± 0.1	+ 2.5 ± 0.1	+ 2.5 ± 0.1	+ 2.5 ± 0.1	@25°C
Span Output (Volts)	± 2.0 ± 0.1	± 2.0 ± 0.1	± 2.0 ± 0.1	± 2.0 ± 0.1	± 2.0 ± 0.2	
Output Loading	> 10 kΩ, < 1 nF	> 10 kΩ, < 1 nF	> 10 kΩ, < 1 nF	> 10 kΩ, < 1 nF	> 10 kΩ, < 1 nF	
<b>Physical</b>						
Standard package						
Size (in)	0.78 x 1.75 x 1.07	0.78 x 1.75 x 1.07	0.78 x 1.75 x 1.07	0.78 x 1.75 x 1.07	0.78 x 1.75 x 1.07	
Size (cm)	1.98 x 4.45 x 2.72	1.98 x 4.45 x 2.72	1.98 x 4.45 x 2.72	1.98 x 4.45 x 2.72	1.98 x 4.45 x 2.72	
Weight	1.62 oz (46 gm)	1.62 oz (46 gm)	1.62 oz (46 gm)	1.62 oz (46 gm)	1.62 oz (46 gm)	
Aluminum package						
Size (in)	0.95 x 2.00 x 1.20	0.95 x 2.00 x 1.20	0.95 x 2.00 x 1.20	0.95 x 2.00 x 1.20	0.95 x 2.00 x 1.20	
Size (cm)	2.41 x 5.08 x 3.05	2.41 x 5.08 x 3.05	2.41 x 5.08 x 3.05	2.41 x 5.08 x 3.05	2.41 x 5.08 x 3.05	
Weight	2.40 oz (68 gm)	2.40 oz (68 gm)	2.40 oz (68 gm)	2.40 oz (68 gm)	2.40 oz (68 gm)	

Notes

<sup>1</sup> -3dB, DC coupled sensor

Sensitivity is ratiometric to supply:  $V_{out} = [Vs/2 + (sensitivity \times Vs/5 \times accel)]$ . Zero g Output is ratiometric to supply, proportional to  $Vs/2$ . Non-linearity is the deviation from a best fit straight line at full scale. Transverse sensitivity is error measured in the primary axis output created by forces induced in the orthogonal axis. Transverse sensitivity error is primarily due to the effects of misalignment. Zero g drift is specified as the typical change in 0 g level from its initial value at +25°C to its worst case value at Tmin or Tmax. Specifications subject to change without notice.

Pin	Color	Function
1	Red	Power In
2	Black	Ground
3	White	X-axis Out
4	Yellow	Y-axis Out
5	Green	Z-axis Out

Pin Diagram

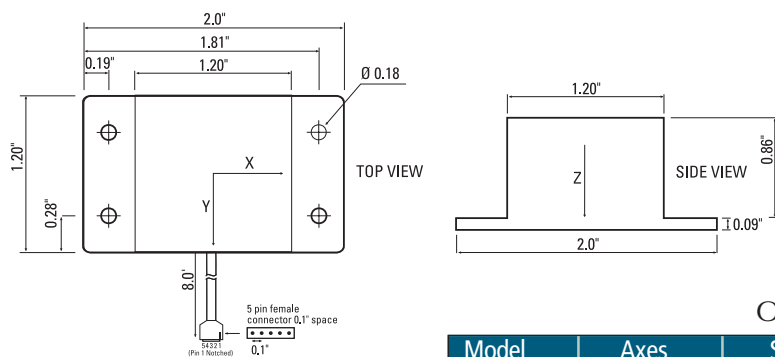

High Temperature Package



Ordering Information

Model	Axes	Span (g)	Sensitivity (mV/g)	Noise (mg rms)	Bandwidth (Hz)
CXL04LP1	X	±4	500	10	DC-100
CXL04LP1Z	Z	±4	500	10	DC-100
CXL04LP3	TRI	±4	500	10	DC-100
CXL10LP1	X	± 10	200	10	DC-100
CXL10LP1Z	Z	± 10	200	10	DC-100
CXL10LP3	TRI	± 10	200	10	DC-100
CXL25LP1	X	±25	80	10	DC-100
CXL25LP1Z	Z	±25	80	10	DC-100
CXL25LP3	TRI	±25	80	10	DC-100
CXL50LP1	X	± 50	40	50	DC-100
CXL50LP1Z	Z	± 50	40	50	DC-100
CXL50LP3	TRI	± 50	40	50	DC-100
CXL100LP1Z	Z	±100	20	80	DC-100
OPTIONS					
-R	Voltage Regulator, 8 – 30 VDC input				
-AL	High Temperature Package (see package drawing above)				